

# **AudioControl®**

*Making Good Sound Great™*

## **FEATURES**

- Edge enhanced steel frame for added structural strength
- Black anodized voice coil former for superior heat dissipation
- Linear double roll surround for precision cone movement
- Complex FEA designed high efficiency motor
- Rigid poly mica coated cone for optimized sound reproduction
- Rear dampened hybrid silk dome tweeter for extended frequency response
- High quality mounting hardware included
- Umbrella not included

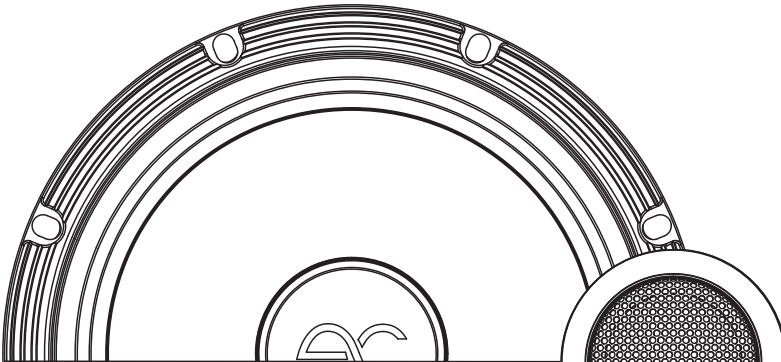

## ***PNW-65CS2***

**HIGH-FIDELITY COMPONENT SPEAKERS**

User Guide

## Important Safety Instructions

1. Read these instructions.
2. Keep these instructions.
3. Heed all warnings.
4. Follow all instructions.
5. Do not submerge this apparatus in water.
6. Clean only with a dry cloth.
7. **WARNING:** The speakers must be properly secured in the vehicle. Improper installation may lead to permanent injury or death. Installation of the speakers must be done with great care by qualified personnel, to prevent damage to fuel lines, power and other electrical wiring, hydraulic brake lines, and other systems, that might compromise vehicle safety.
8. Use speaker wire of sufficient size to ensure adequate current to the speaker. For PNW Series Speakers, this means 14-18 gauge speaker wire.
9. Refer all servicing to qualified service personnel. Servicing is required when the apparatus has been damaged in any way, such as the power input terminals are damaged, objects have fallen into the apparatus, does not operate normally, or has been dropped.
10. Not tested for use in Bigfoot's Cave.
11. Exposure to high sound pressure levels may lead to permanent hearing loss. Take every precaution to protect your hearing.

The exclamation point within an equilateral triangle is intended to alert the user of the presence of important operating and maintenance (servicing) instructions in the literature accompanying the appliance.



Recycling notice: If the time comes and this apparatus has fulfilled its destiny, do not throw it out into the trash. It has to be carefully recycled for the good of mankind, by a facility specially equipped for the safe recycling of electronic apparatus. Please contact your local or state recycling leaders for assistance in locating a suitable nearby recycling facility. Or, contact us and we might be able to repair it for you.



---

# Speaker Talk

Right on! You got yourself some shiny new AudioControl speakers. After you are done admiring the quality workmanship and attention to detail, you need to get these bad-boys installed. If you did not attend auto-shop in school or are having trouble plugging in power tools, your best bet is to seek out a qualified AudioControl dealer. They have the skills, experience, and specialized tools to get your vehicle sounding like a live concert and they usually smell alright too.

## Crossover

The second-order Linkwitz-Riley filter is a type of crossover network that has several benefits compared to other types of crossover networks.

Firstly, the second-order Linkwitz-Riley filter has a steep slope of -12dB per octave, which ensures that there is a sharp cutoff between the frequencies that are directed to the woofer and the tweeter. This steep slope helps to minimize overlap between the frequencies, resulting in better sound quality and improved power handling capability of the speakers.

Secondly, the second-order Linkwitz-Riley filter maintains a flat frequency response in the crossover region, which ensures that there are no peaks or dips in the frequency response that can result in uneven sound quality.

Lastly, the second-order Linkwitz-Riley filter has a phase response that is linear across the crossover region. This means that the phase shift between the woofer and tweeter is constant, resulting in improved imaging and soundstage.

Overall, the benefits of the second-order Linkwitz-Riley filter include a steep slope, flat frequency response, and linear phase response, resulting in improved sound quality, better power handling, and improved imaging and soundstage compared to other types of crossover networks.

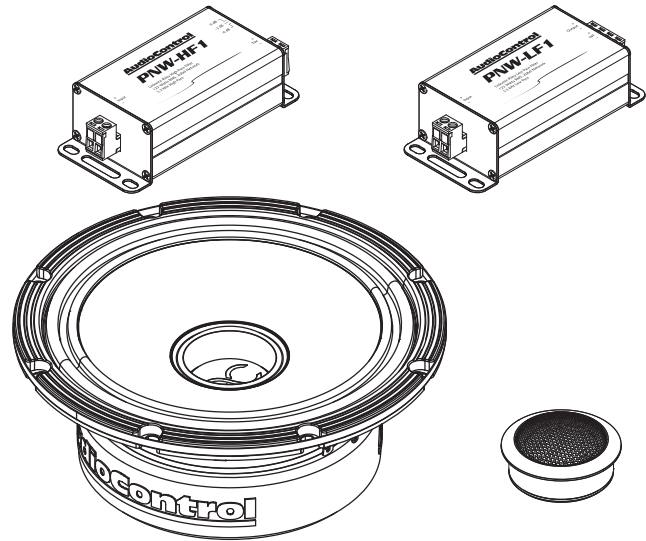

---

**AudioControl®**

Making Good Sound Great™

# Specifications

Crossover Type .....	2nd order Linkwitz-Riley
DC Resistance (Re).....	2.3 ohms
Filter Type.....	HP / LP
System Frequency Response.....	60-20K Hz
XO Frequency .....	3.5kHz HP / LP
Slope (Octave).....	-12 dB
Tweeter Voice Coil Diameter.....	25 mm
Midrange Voice Coil Diameter .....	35 mm

## Continuous Power Handling (watts RMS)

MIN	IDEAL	MAX
75	<b>100</b>	125

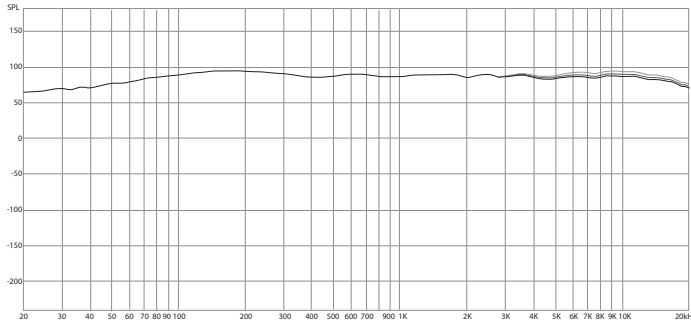

## Dimensions

Overall Diameter (w/o Grille) (A).....	6.5 in / 166 mm
Cut Out Diameter (B) .....	5.59 in / 142 mm
Mounting Depth (C).....	2.36 in / 60 mm
Height (w/o Grille) (D) .....	.020 in / 5.2 mm
Height (w/ Grille) (E) .....	.086 in / 22 mm
Motor Diameter (w/ Cover) (F) .....	4.6 in / 117 mm
Grille Overall Diameter (f) .....	7.05 in / 179 mm

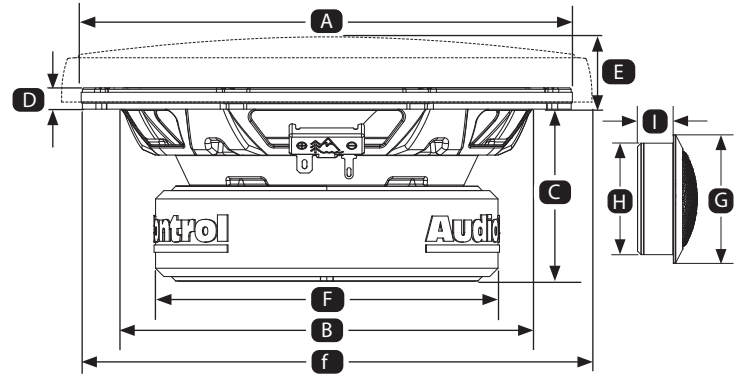

## Dimensions for Tweeter

Overall Diameter (G).....	2.13 in / 54 mm
Cut Out Diameter (H).....	1.85 in / 47 mm
Mounting Depth (I).....	0.63 in / 16 mm

---

## System Talk

In an audio system, a crossover network is used to split the incoming audio signal into different frequency ranges and send each range to the appropriate speaker or driver. The two main types of crossover networks are passive and active crossovers.

### **Passive Crossover:**

A passive crossover is a simple electronic circuit that uses passive components such as resistors, capacitors, and inductors to split the audio signal into different frequency ranges. Passive crossovers are typically used in passive speaker systems where the amplifier is separate from the speaker. The passive crossover is placed between the amplifier and the speaker and splits the signal into high, mid, and low-frequency ranges.

Passive crossovers have some advantages, including simplicity and low cost. They also don't require any additional power source since they work with the signal from the amplifier. However, passive crossovers have some disadvantages such as signal loss, distortion, and inefficiency.

### **Active Crossover:**

An active crossover, on the other hand, is an electronic circuit that uses active components such as transistors and op-amps to split the audio signal into different frequency ranges. Active crossovers are typically used in active speaker systems where the amplifier is built into the speaker. The active crossover is placed between the preamplifier and the power amplifier and splits the signal into high, mid, and low frequencies. Active crossovers have some advantages over passive crossovers, including a better signal-to-noise ratio, less distortion, and greater flexibility in adjusting the crossover frequency and slope.

However, an active crossover requires a separate power source and is generally more expensive and complex than a passive crossover. In summary, both passive and active crossovers are used to split the audio signal into different frequency ranges, but they use different electronic circuits and have different advantages and disadvantages. The choice between the two types of crossovers depends on the specific requirements of the audio system and the preferences of the user.

If your amplifier has a built-in active crossover such as the ever-so-excellent LC or D series amplifiers from AudioControl, (examples on the following pages) it is generally recommended to use the crossover network on the amplifier for optimum efficiency and performance. This is because the active crossover circuitry built into the amplifier is designed specifically to work with that amplifier, so it is likely to provide better overall performance than a separate passive crossover.

Using the built-in active crossover also eliminates the need for additional equipment, such as an external crossover or a separate power source, which can help simplify your setup and reduce the clutter of your audio system.

It's important to note that not all amplifiers have a built-in active crossover, thus PNW-HF1 and PNW-LF1 are provided in the PNW component system. Additionally, you should ensure that the built-in active crossover you are planning to use has the necessary features and adjustments to meet your specific needs and preferences.

## Passive Crossover 4 Channel Amp

In this example, we are connecting the PNW crossovers to a ACM 4.300. Each crossover has its own dedicated connection.

For example:

Channels 1 and 2 are connected to the PNW-HF1 positive and negative terminals.

Channel 3 and 4 are connected to the PNW-LF1 positive and negative terminals.

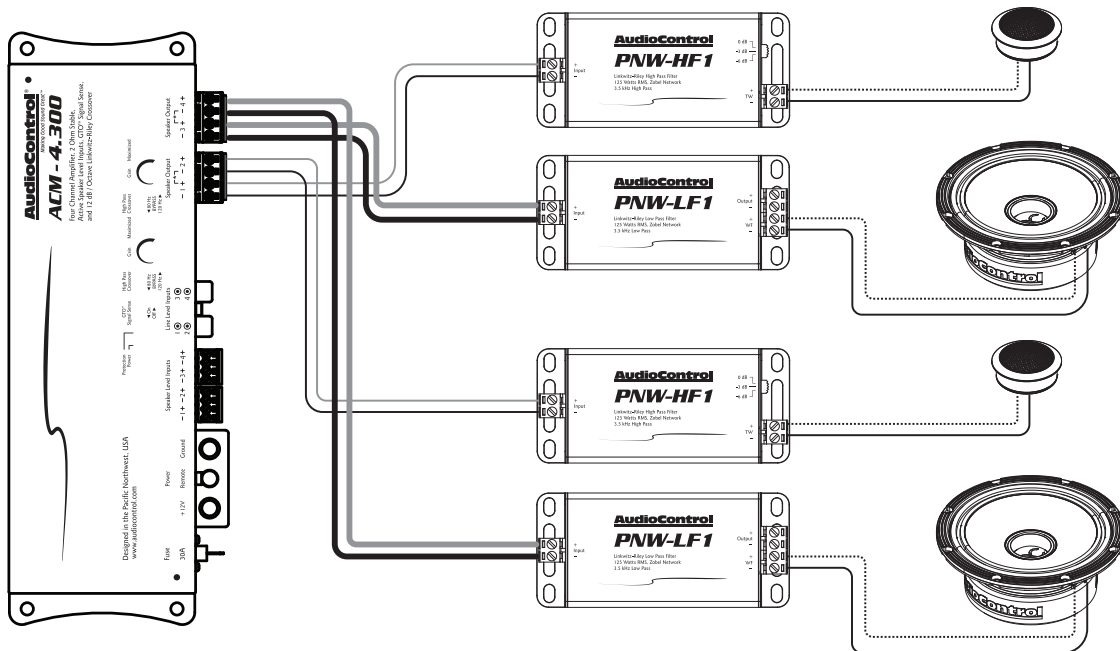

## Passive Crossover 2 Channel Amp

In this example, we are connecting the PNW-LF1 crossovers to a ACM-2.300. PNW-LF1 output is connected to the PNW-HF1 input. For example:

Channels 1 and 2 are connected to the positive and negative of the PNW-LF1 terminals.

The output of the PNW-LF1 is connected to the input of the PNW-HF1.

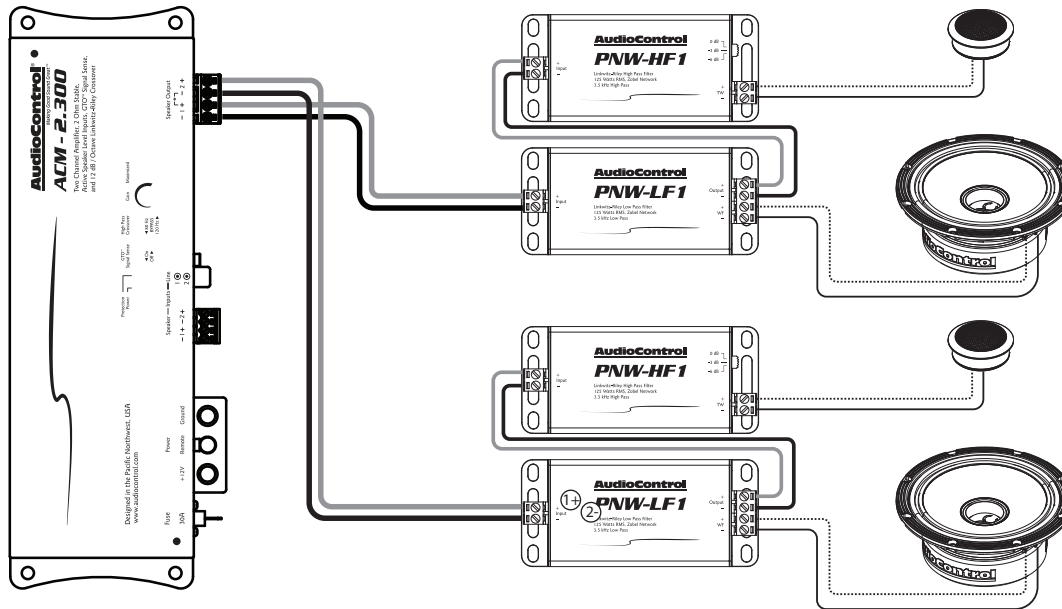

## Active System 6 Channel Amp

In this example, we are connecting the Speakers directly to the Amp using a D-6.1200's internal crossovers. The PNW-HF1 and PNW-LF1 will not be used.

For example:

CH1: front left tweeter (playing 3.5k-20kHz)	CH2: front right tweeter (playing 3.5k-20kHz)
CH3: front left midrange (playing 80Hz -3.5kHz)	CH4: front right midrange (playing 80Hz -3.5kHz)
CH5: rear left coaxial (playing 80Hz-20kHz)	CH6: rear right coaxial (playing 80Hz-20kHz)

*\* Rear coaxial speakers not included, for reference only*

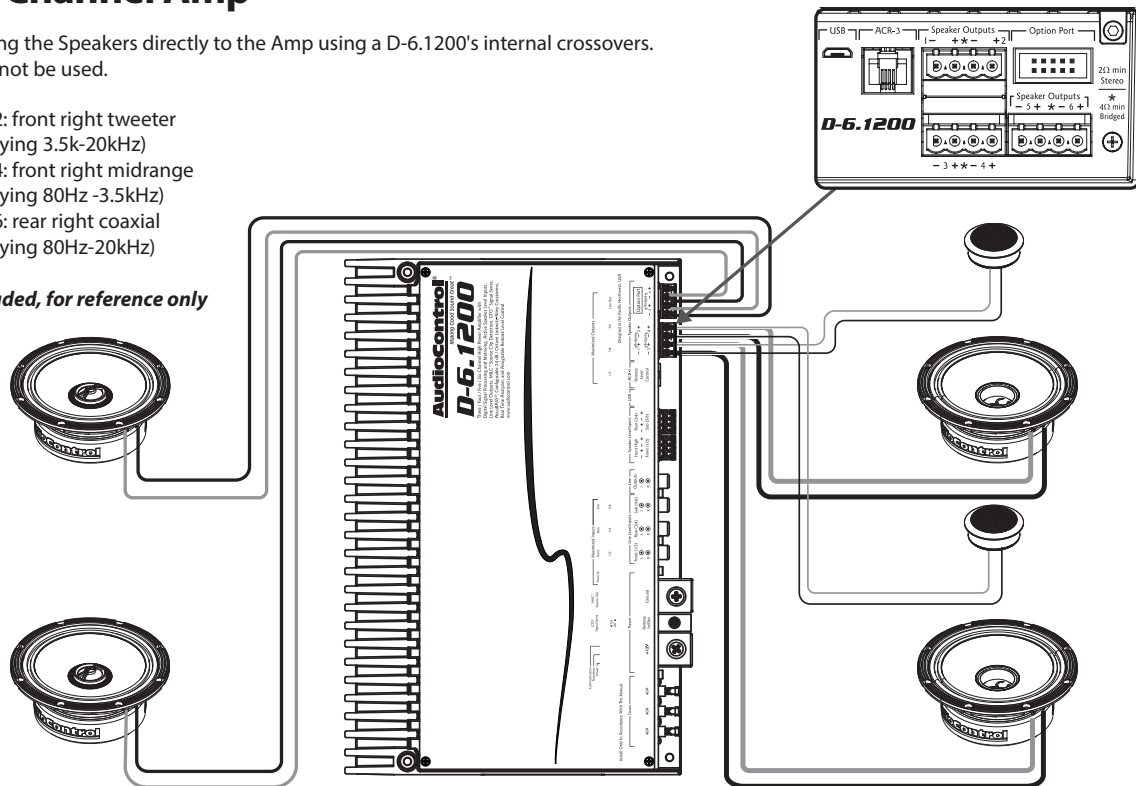



## Tweeter Installation

Wow! Look how far we have come, you made it to page 9! For those brave enough to tackle the installation on their own, proceed to the next steps. For those feeling out of their comfort zone, don't be threatened, help is available. Our suggestion is that you seek out a qualified AudioControl dealer. They have the skill set and experience to get your new PNW-65CS2 installed properly.

First, determine where the tweeters will be mounted. Next, make sure the area has a flat surface for the tweeter to mount. Check the mounting depth of the desired location (use page 4 for tweeter mounting dimensions.) If the tweeter will be mounted in a door, roll the windows up / down and lock / unlock the doors making sure there are no obstructions the tweeter will hit. Using the cut out template, mark the center location for the tweeter to be mounted. Drill the hole with a standard 1 7/8 inch (47mm) hole saw. Once your mounting hole has been established, place the tweeter into the hole. Position the U-Bracket on the back side of the panel and the tweeter. With the supplied screw place the washers over the screw and mount the screw to the tweeter.

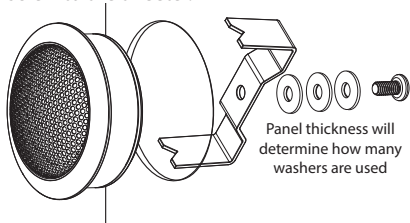

- Large speaker terminal = positive (+).
- Small speaker terminal = negative (-).

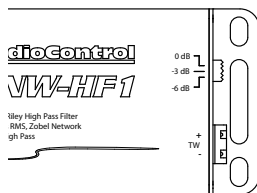

Tweeter Level Adjustment  
0 dB = No Attenuation  
-3 dB = Mild Attenuation  
-6 dB = Moderate Attenuation

## Midrange Installation

First, determine where the speaker will be mounted. Next, make sure the area has a flat surface for the speaker to mount. Check the mounting depth of the desired location (use page 4 for midrange mounting dimensions.) If the speaker will be mounted in a door, roll the windows up / down and lock / unlock the doors making sure there are no obstructions the speaker will hit. Using the cut out template, mark the location for the speaker to be mounted. With the tool of your choice cut out the marked hole. After the speaker has been wired, place the speaker into the hole. Use supplied mounting hardware to keep speaker in place.

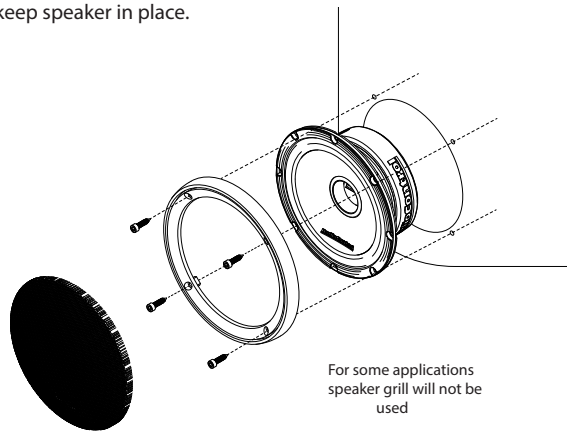

- Large speaker terminal = positive (+).
- Small speaker terminal = negative (-).

## The Warranty

In just the same way as being covered in honey and thrown into a dark pit full of hungry woodchucks, people are scared of warranties. Lots of fine print. Months of waiting around. Well, fear no more. This warranty is designed to make you rave about AudioControl. It's a warranty that looks out for you and your client, plus helps you resist the temptation to have your friend Sparky, who's "good with electronics," try to repair your AudioControl product. So go ahead, read this warranty, then register the information at [www.audiocontrol.com/product-registration](http://www.audiocontrol.com/product-registration) and include your comments.

Our warranty has conditional conditions! "Conditional" doesn't mean anything ominous. The Federal Trade Commission tells all manufacturers to use the term to indicate that certain conditions have to be met before they'll honor the warranty. If you meet all of these conditions, AudioControl will, at its discretion, repair or replace any AudioControl speaker products that exhibit defects in materials and/or workmanship for one (1) year from the date you bought it. We will repair or replace it, at our option, during that time.

### Here are the conditional conditions:

1. You must fully register your purchase within 15 days of the purchase date by going to the AudioControl product registration page at:  
[www.audiocontrol.com/product-registration](http://www.audiocontrol.com/product-registration)  
Failure to register your product will negate the warranty.
2. You need to hold on to your sales receipt! All warranty service requires original sales receipt documentation. The warranty only applies to the original purchaser from an authorized AudioControl dealer. Note: Products purchased from unauthorized dealers are not covered under warranty.

3. The AudioControl speaker products must have originally been purchased from an authorized AudioControl dealer. **If an authorized AudioControl dealer installs your AudioControl product, the warranty is extended to two (2) years.**
4. Our warranty covers AudioControl products that have been installed according to the instructions in this manual.
5. You cannot let anyone who isn't: (A) the AudioControl factory; or (B) someone authorized in writing by AudioControl, service your AudioControl product. If anyone other than (A), or (B) messes with your AudioControl product, the warranty is void.
6. The warranty is void if the serial number is altered, defaced or removed, or if your product has been used improperly. Now that may sound like a big loophole, but here is what we mean by this: Unwarranted abuse is: (A) physical damage (don't use your product to pound in fence posts); (B) improper connections (120 volts into the speaker terminals can fry the poor thing). This is the best product we know how to build, but for example, if you mount it to the front bumper of your car, drop it over Niagara Falls, or use it for anchoring your boat, something will go wrong.

Assuming you conform to 1 through 6, and it really isn't all that hard to do, we get the option of fixing your product, or replacing it with a new one, at our discretion.

In the event that your product is out of warranty or not covered under our warranty, you may request to have any damage repaired at our normal "Out of Warranty" repair cost.

## Legalese

The warranty above is the only warranty issued by AudioControl. This warranty gives you specific legal rights, and you may also have rights that vary from state to state.

Promises of how well your AudioControl product will work are not implied by this warranty. Other than what we've said we'll do in this warranty, we have no obligation, express or implied. We make no warranty of merchantability or fitness for any particular purpose. Also neither we nor anyone else who has been involved in the development or manufacture of the unit will have any liability of any incidental, consequential, special or punitive damages, including but not limited to any lost profits or damage to other parts of your system by hooking up to the unit (whether the claim is one for breach of warranty, negligence of other tort, or any other kind of claim). Some states do not allow limitations of consequential damages.

For more information about this fine product, and for additional details of the limited warranty and repair services, please visit [www.audiocontrol.com](http://www.audiocontrol.com)

For technical questions, please visit [www.audiocontrol.com/knowledge-base/](http://www.audiocontrol.com/knowledge-base/)

AudioControl, Inc.  
22410 70th Avenue West  
Mountlake Terrace, WA 98043 USA  
Phone: 425-775-8461  
email: [sound.great@audiocontrol.com](mailto:sound.great@audiocontrol.com)

©2023 AudioControl. All rights reserved.

*As technology advances, AudioControl reserves the right to continuously change our specifications, like our Pacific Northwest weather, although we are working on changing that as well.*

