

# **AudioControl®**

*Making Good Sound Great™*

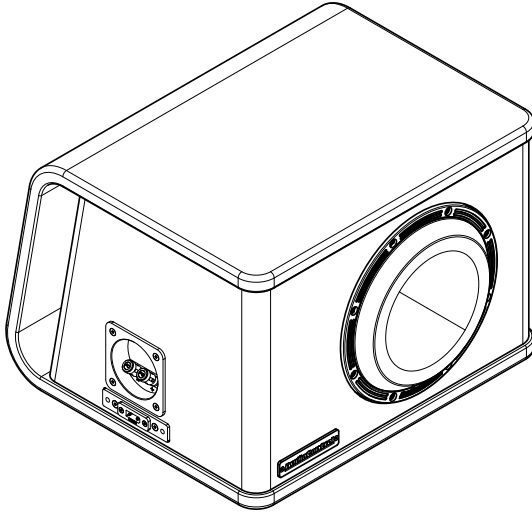

## **Features**

- Rugged enclosure with Internal bracing
- Roadkill-Armor Coated surface
- Wrapped in durable, marine-grade vinyl
- SPK-8S2 8" Subwoofer
- Optimum bass output design
- Structurally rigid heavy duty voice coil
- Fiber matrix paper cone with Mica coating
- 500 Watts RMS Maximum Power handling

Spike™ Series

VENTED ENCLOSURE

SPK-V8

---

User Guide



## Important Safety Instructions

1. Read these instructions.
2. Keep these instructions.
3. Heed all warnings.
4. Follow all instructions.
5. Do not submerge this apparatus in water.
6. Clean only with a dry cloth.
7. **WARNING:** The subwoofer enclosure must be properly secured in the vehicle. Improper installation may lead to permanent injury or death. Installation of the speaker enclosure must be done with great care by qualified personnel, to prevent damage to fuel lines, power and other electrical wiring, hydraulic brake lines, and other systems, that might compromise vehicle safety.
8. Use speaker wire of sufficient size to ensure adequate current to the speaker. For Space Series Subwoofers, this means 10-14 gauge speaker wire.
9. To prevent excessive cone excursion and potential damage to the subwoofer is it advisable to use a infrasonic (subsonic) filter set 1/2 octave below Fb. (Hz)
10. Refer all servicing to qualified service personnel. Servicing is required when the apparatus has been damaged in any way, such as the power input terminals are damaged, objects have fallen into the apparatus, does not operate normally, or has been dropped.
11. Not tested for use in outer space.
12. Exposure to high sound pressure levels may lead to permanent hearing loss. Take every precaution to protect your hearing.

The exclamation point within an equilateral triangle is intended to alert the user of the presence of important operating and maintenance (servicing) instructions in the literature accompanying the appliance.



Recycling notice: If the time comes and this apparatus has fulfilled its destiny, do not throw it out into the trash. It has to be carefully recycled for the good of mankind, by a facility specially equipped for the safe recycling of electronic apparatus. Please contact your local or state recycling leaders for assistance in locating a suitable nearby recycling facility. Or, contact us and we might be able to repair it for you.



---

## Enclosure Talk

Right on! You got yourself a shiny new AudioControl enclosure. After you're done admiring the quality workmanship and attention to detail, you need to get this earth shaking enclosure installed. If you did not attend auto-shop in school or are having trouble plugging in power tools, your best bet is to seek out a qualified AudioControl dealer. They have the skills, experience, and specialized tools to get your vehicle sounding like a live concert and they usually smell alright, too.

When you provide your subwoofer with too much power, it can lead to distortion and potential damage. **Overpowering** causes the cone to move outward beyond its intended limits, resulting in issues such as tearing of the cone, spider, and surround, ultimately destroying the subwoofer. Conversely, if the signal instructs the voice coil to move too far backward, it may crash into the back plate of the magnet assembly, causing damage to the coil and former. To avoid potentially damaging your subwoofer, it is crucial to match the RMS power ratings of your subwoofer and amplifier accurately. Additionally, setting the amplifier's gain correctly helps prevent distortion and excessive power delivery.

**Underpowering** a subwoofer itself is not harmful, but it can lead to issues when the power is supplied by an amplifier that sends out a clipped signal. Clipping occurs when the volume of the source signal exceeds the electronic capability of a circuit, resulting in distortion. A clipped signal tries to move the cone too quickly, causing the subwoofer to attempt rapid and excessive movements. This can lead to damage or jamming of the voice coil. A clipped signal instructs the voice coil to hold still for extended periods, causing it to heat up. This can result in overheating, deformation, and damage to the voice coil of the subwoofer. To prevent damage from underpowering, ensure your amplifier is not overworked and sending out a clipped signal. Matching the RMS power ratings and setting the crossover correctly are vital steps to avoid distortion, protect your subwoofer, and ensure peak performance.

**Over excursion** refers to pushing a subwoofer past its mechanical limits. Subwoofers are more susceptible to over-excursion due to their need for significant cone movement to produce low frequencies.

**Proper Break-In:** Give your subwoofer's suspension time to stabilize by following the recommended break-in period. This ensures the suspension components, such as spiders and surrounds, exhibit control and longevity.

Understanding subwoofer performance and taking the necessary steps to prevent damage is crucial for achieving the best audio experience and ensuring the longevity of your subwoofer. Proper break-in, and subsonic crossover usage are essential practices to prevent damage. By following these guidelines and avoiding distortion, you can enjoy powerful and precise bass without compromising your subwoofer's performance and longevity.

Please visit AudioControl knowledge base site for detailed break-in procedures.

<https://www.audiocontrol.com/knowledge-base>



## Quick Plug Harness

The enclosure comes with two different types of connections:  
**Only one connection method is needed. Both terminals are connected internally to the subwoofer.**

### 1. Quick-Plug harness

This harness has a red and black 12-gauge wire.

Red = Positive / Black = Negative

Each wire has already been tinned with solder.  
We recommend using solder and heat-shrink for the optimal connection.  
Once soldered and heat-shrunk, lift the rubber cover and plug in the harness.

### 2. Standard speaker push terminals

Strip your speaker wire at least 1/2 inch to expose the copper or silver strands.

Push down on each terminal and insert your wire.

Red = Positive / Black = Negative

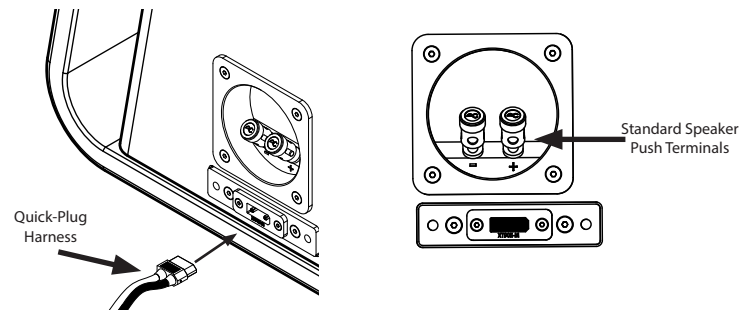

## Enclosure Mounting

**When mounting the enclosure to the vehicle, look for any electrical or fuel lines and avoid them at all costs before drilling holes and mounting.**

Mount the bracket to the enclosure using the included M6 x 8mm screw.  
Each left and right brackets mounts to the enclosure using 1 screw.  
Once the bracket is mounted use the M5 self-taping screw to hold it in place.

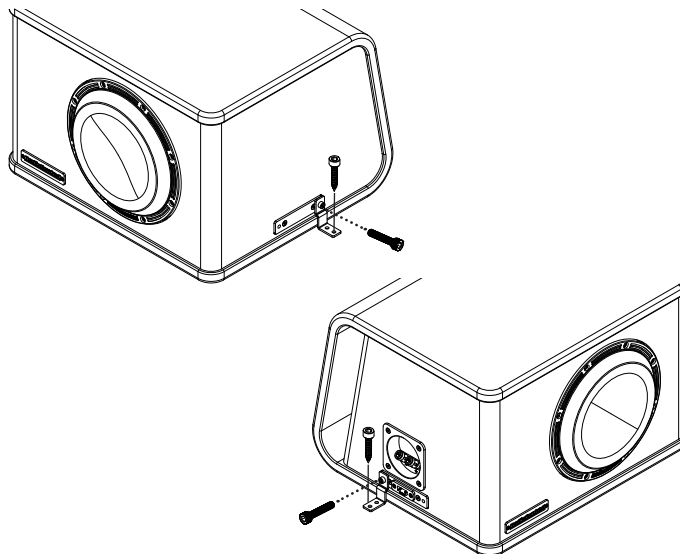

# Specifications

Woofer Size .....8 in  
 Subwoofer Model.....SPK-8S2  
 Frequency Response ..... 25-150 Hz  
 Sensitivity ..... 83.4 dB  
 Enclosure Type ..... Ported  
 Subsonic Filter Setting ..... 33 Hz  
 Enclosure Tuning Frequency..... 44 Hz  
 F3 Frequency @-3dB..... 39 Hz  
 Terminal Wire acceptance ..... 12-8 Gauge

RMS Watts ..... 

MIN	IDEAL	MAX
200	350	500

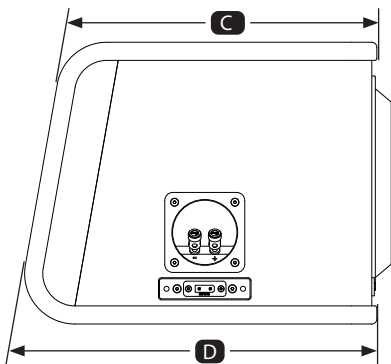

## Dimensions

Enclosure Width (A) ..... 15.75 in  
 Enclosure Height (B)..... 11.02 in  
 Enclosure Depth (top) (C) ..... 12.13 in  
 Enclosure Depth (bottom) (D).....13.74 in

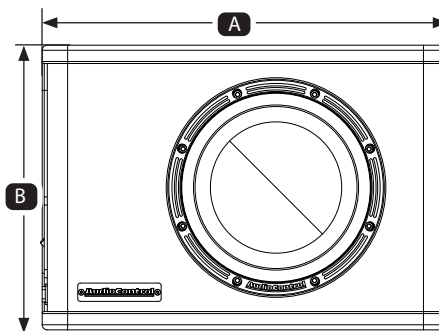

**AudioControl®**

*Making Good Sound Great™*



## The Warranty

In just the same way as being covered in honey and thrown into a dark pit full of hungry woodchucks, people are scared of warranties. Lots of fine print. Months of waiting around. Well, fear no more. This warranty is designed to make you rave about AudioControl. It's a warranty that looks out for you and your client, plus helps you resist the temptation to have your friend Sparky, who's "good with electronics," try to repair your AudioControl product. So go ahead, read this warranty, then register the information at [www.audiocontrol.com/product-registration](http://www.audiocontrol.com/product-registration) and include your comments.

Our warranty has conditional conditions! "Conditional" doesn't mean anything ominous. The Federal Trade Commission tells all manufacturers to use the term to indicate that certain conditions have to be met before they'll honor the warranty. If you meet all of these conditions, AudioControl will, at its discretion, repair or replace any AudioControl speaker product that exhibit defects in materials and/or workmanship during the warranty on your product for one (1) year from the date you bought it, and we will fix or replace it, at our option, during that time.

### Here are the conditional conditions:

1. You must fully register your purchase within 15 days of the purchase date by going to the AudioControl product registration page at:  
[www.audiocontrol.com/product-registration](http://www.audiocontrol.com/product-registration)  
Failure to register your product will negate the warranty.
2. You need to hold on to your sales receipt! All warranty service requires original sales receipt documentation. The warranty only applies to the original purchaser from an authorized AudioControl dealer. Note: Products purchased from unauthorized dealers are not covered under warranty.

3. The AudioControl speaker products must have originally been purchased from an authorized AudioControl dealer. **If an authorized AudioControl dealer installs your AudioControl product, the warranty is two (2) years.**
4. Our warranty covers AudioControl products that have been installed according to the instructions in the installation manual.
5. You cannot let anybody who isn't: (A) the AudioControl factory; or (B) somebody authorized in writing by AudioControl, service your AudioControl product. If anyone other than (A), or (B) messes with your AudioControl product, the warranty is void.
6. The warranty is void if the serial number is altered, defaced or removed, or if your product has been used improperly. Now that may sound like a big loophole, but here is what we mean by this: Unwarranted abuse is: (A) physical damage (don't use your product to pound in fence posts); (B) improper connections (120 volts into the speaker terminals can fry the poor thing). This is the best product we know how to build, but for example, if you mount it to the front bumper of your car, drop it over Niagara Falls or use it for anchoring your boat, something will go wrong.

Assuming you conform to 1 through 6, and it really isn't all that hard to do, we get the option of fixing your product or replacing it with a new one at our discretion.

In the event that your product is out of warranty or not covered under our warranty you may request to have any damage repaired at our normal "Out of Warranty" repair cost.

## Legalese

The warranty above is the only warranty issued by AudioControl. This warranty gives you specific legal rights, and you may also have rights that vary from state to state.

Promises of how well your AudioControl product will work are not implied by this warranty. Other than what we've said we'll do in this warranty, we have no obligation, express or implied. We make no warranty of merchantability or fitness for any particular purpose. Also, neither we nor anyone else who has been involved in the development or manufacture of the unit will have any liability for any incidental, consequential, special, or punitive damages, including but not limited to any lost profits or damage to other parts of your system by hooking up to the unit (whether the claim is one for breach of warranty, negligence of other tort, or any other kind of claim). Some states do not allow limitations of consequential damages.

For more information about this fine product, and for additional details of the limited warranty and repair services, please visit [www.audiocontrol.com](http://www.audiocontrol.com)

For technical questions, please visit [www.audiocontrol.com/knowledge-base/](http://www.audiocontrol.com/knowledge-base/)

AudioControl, Inc.

Phone: 425-777-7723

Email: [support@audiocontrolmobile.com](mailto:support@audiocontrolmobile.com)

©2023 AudioControl. All rights reserved. AudioControl is a brand of AAMP Global.

*All specifications are subject to being covered in hot sauce without notice.*

*As technology advances, AudioControl reserves the right to continuously change our specifications, like our Pacific Northwest weather, although we are working on changing that as well.*

