

AudioControl®

Making Good Sound Great™

FEATURES

- Edge-enhanced steel frame for added structural strength
- Black anodized voice coil former for superior heat dissipation
- Linear double-roll surround for precision cone movement
- Complex FEA designed high-efficiency motor
- Rigid poly mica-coated cone for optimized sound reproduction
- Rear dampened hybrid silk dome tweeter for extended frequency response
- Concentric point source design for a seamless transition from midrange to tweeter
- Sonic diffuser and radiant collar for better off-axis frequency response
- High-quality mounting hardware included
- Umbrella not included

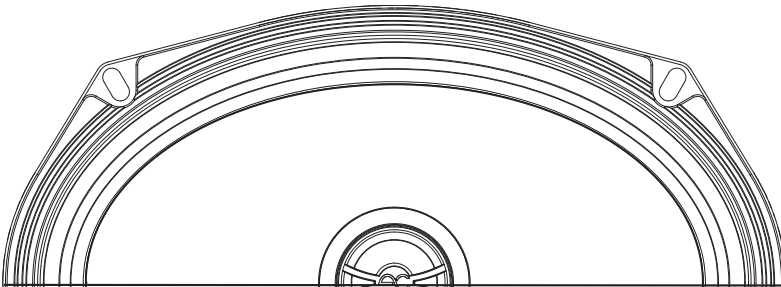

PNW-69
HIGH-FIDELITY COAXIAL SPEAKERS

User Guide

Important Safety Instructions

1. Read these instructions.
2. Keep these instructions.
3. Heed all warnings.
4. Follow all instructions.
5. Do not submerge this apparatus in water.
6. Clean only with a dry cloth.
7. **WARNING:** The speakers must be properly secured in the vehicle. Improper installation may lead to permanent injury or death. Installation of the speakers must be done with great care by qualified personnel, to prevent damage to fuel lines, power and other electrical wiring, hydraulic brake lines, and other systems, that might compromise vehicle safety.
8. Use speaker wire of sufficient size to ensure adequate current to the speaker. For PNW Series Speakers, this means 14-18 gauge speaker wire.
9. Refer all servicing to qualified service personnel. Servicing is required when the apparatus has been damaged in any way, such as the power input terminals are damaged, objects have fallen into the apparatus, does not operate normally, or has been dropped.
10. Not tested for use in Bigfoot's Cave.
11. Exposure to high sound pressure levels may lead to permanent hearing loss. Take every precaution to protect your hearing.

The exclamation point within an equilateral triangle is intended to alert the user of the presence of important operating and maintenance (servicing) instructions in the literature accompanying the appliance.



Recycling notice: If the time comes and this apparatus has fulfilled its destiny, do not throw it out into the trash. It has to be carefully recycled for the good of mankind, by a facility specially equipped for the safe recycling of electronic apparatus. Please contact your local or state recycling leaders for assistance in locating a suitable nearby recycling facility. Or, contact us and we might be able to repair it for you.



Speaker Talk

Right on! You got yourself some shiny new AudioControl speakers. After you're done admiring the quality workmanship and attention to detail, you need to get these bad-boys installed. If you did not attend auto-shop in school or are having trouble plugging in power tools, your best bet is to seek out a qualified AudioControl dealer. They have the skills, experience, and specialized tools to get your vehicle sounding like a live concert and they usually smell alright too.

Crossover

The 1st order series resistor crossover network is an effective solution for dividing the audio frequency spectrum between the woofer and tweeter. One of the main benefits of using a 1st order series resistor crossover network is that it maintains a relatively constant impedance, which can be advantageous for certain amplifier and speaker combinations.

Another benefit of using a 1st order series resistor crossover network is that it can be used to protect the tweeter from damage. By adding a resistor in series with the tweeter, the power delivered to the tweeter can be limited, which can help to prevent it from being overloaded and potentially damaged. This can be particularly important in high-powered audio systems. Additionally, the use of a series resistor can help to mitigate phase issues between the woofer and tweeter, resulting in improved sound quality.

First-order crossovers have very shallow slopes - 6dB per octave. That means if your crossover is at 2,000Hz, then at 1,000Hz, one octave down, the tweeter is still getting 1/4 of the music power; at 500Hz, two octaves down, the tweeter is getting 1/16th of the music power, about 6%.

In summary, the benefits of using a 1st order series resistor crossover network include a relatively constant impedance, protection for the tweeter, simplicity of design and implementation, and potential improvement in sound quality.

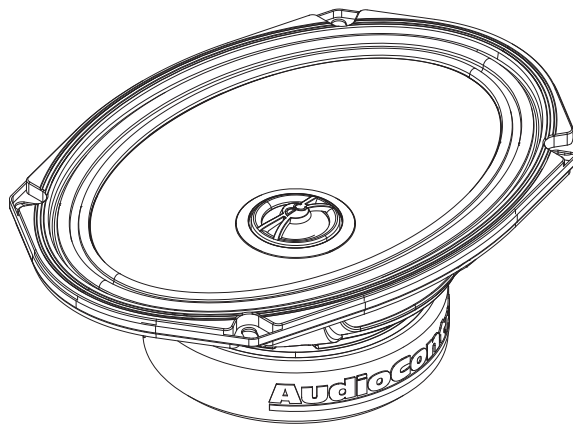

AudioControl®

Making Good Sound Great™



Specifications

| | |
|-----------------------------------|-------------|
| Crossover Type | Butterworth |
| DC Resistance (Re)..... | 2.6 ohms |
| Filter Type..... | HP |
| System Frequency Response..... | 50-20K Hz |
| XO Frequency | 5250 Hz |
| Slope (Octave)..... | -6 dB |
| Tweeter Voice Coil Diameter..... | 20 mm |
| Midrange Voice Coil Diameter..... | 35 mm |

Continuous Power Handling (watts RMS)

| MIN | IDEAL | MAX |
|-----|-------|-----|
| 50 | 75 | 100 |

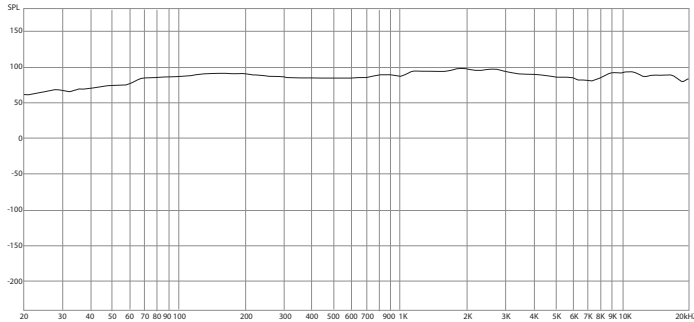

Dimensions

| | |
|--|-------------------------------|
| Overall Diameter (w/o Grille) (A)(a) | 6 x 9 in / 167 x 235 mm |
| Overall Diameter (w Grille) (A)(a)..... | 7.2 x 10.43 in / 183 x 265 mm |
| Cut Out Diameter (B)(b) | 5.74 x 8.34 in / 146 x 212 mm |
| Mounting Depth (C)..... | 2.95 in / 75 mm |
| Height (w/o Grille) (D) | 0.24 in / 6.3 mm |
| Height (w/ Grille) (E) | 0.98 in / 25 mm |
| Motor Diameter (w/ Cover) (F) | 4.6 in / 117 mm |

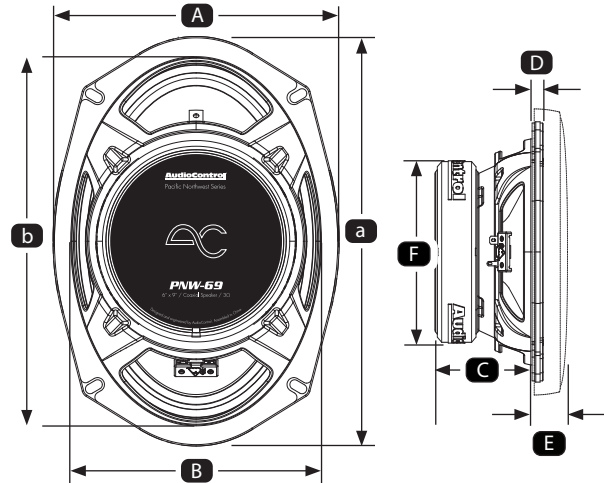

Factory Location Installation

Wow! Look how far we have come, you made it to page 5! For those brave enough to tackle the installation on their own, proceed to the next steps. For those feeling out of their comfort zone, don't be threatened, help is available. Our suggestion is that you seek out a qualified AudioControl dealer. They have the skill set and experience to get your new PNW-69 installed properly.

First, remove the factory grille or panel to gain access to the factory speaker. Next, remove the factory speaker and disconnect the necessary wiring. After the speaker has been wired, mount the speaker where you removed the factory speaker using the factory speaker hardware.

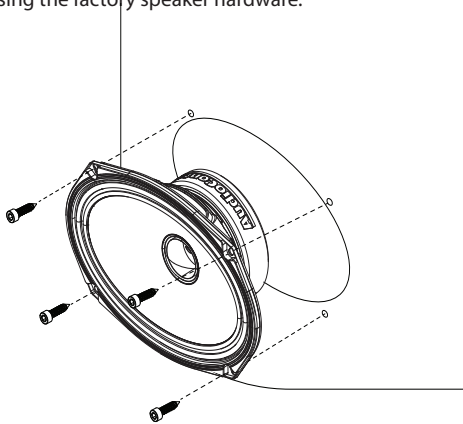

- Large speaker terminal = positive (+).
- Small speaker terminal = negative (-).

Custom Location Installation

First, determine where the speaker will be mounted. Next, make sure the area has a flat surface for the speaker to mount. Check the mounting depth of the desired location (use page 4 for midrange mounting dimensions.) If the speaker will be mounted in a door, roll the windows up / down and lock / unlock the doors making sure there are no obstructions the speaker will hit. Using the cut out template, mark the location for the speaker to be mounted. With the tool of your choice cut out the marked hole. After the speaker has been wired, place the speaker into the hole. Use supplied mounting hardware to keep speaker in place.

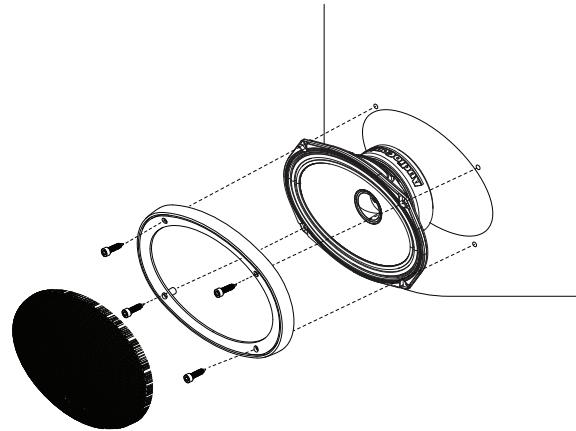

- Large speaker terminal = positive (+).
- Small speaker terminal = negative (-).

The Warranty

In just the same way as being covered in honey and thrown into a dark pit full of hungry woodchucks, people are scared of warranties. Lots of fine print. Months of waiting around. Well, fear no more. This warranty is designed to make you rave about AudioControl. It's a warranty that looks out for you and your client, plus helps you resist the temptation to have your friend Sparky, who's "good with electronics," try to repair your AudioControl product. So go ahead, read this warranty, then register the information at www.audiocontrol.com/product-registration and include your comments.

Our warranty has conditional conditions! "Conditional" doesn't mean anything ominous. The Federal Trade Commission tells all manufacturers to use the term to indicate that certain conditions have to be met before they'll honor the warranty. If you meet all of these conditions, AudioControl will, at its discretion, repair or replace any AudioControl speaker products that exhibit defects in materials and/or workmanship for one (1) year from the date you bought it. We will repair or replace it, at our option, during that time.

Here are the conditional conditions:

1. You must fully register your purchase within 15 days of the purchase date by going to the AudioControl product registration page at:
www.audiocontrol.com/product-registration
Failure to register your product will negate the warranty.
2. You need to hold on to your sales receipt! All warranty service requires original sales receipt documentation. The warranty only applies to the original purchaser from an authorized AudioControl dealer. Note: Products purchased from unauthorized dealers are not covered under warranty.

3. The AudioControl speaker products must have originally been purchased from an authorized AudioControl dealer. **If an authorized AudioControl dealer installs your AudioControl product, the warranty is extended to two (2) years.**
4. Our warranty covers AudioControl products that have been installed according to the instructions in this manual.
5. You cannot let anyone who isn't: (A) the AudioControl factory; or (B) someone authorized in writing by AudioControl, service your AudioControl product. If anyone other than (A), or (B) messes with your AudioControl product, the warranty is void.
6. The warranty is void if the serial number is altered, defaced or removed, or if your product has been used improperly. Now that may sound like a big loophole, but here is what we mean by this: Unwarranted abuse is: (A) physical damage (don't use your product to pound in fence posts); (B) improper connections (120 volts into the speaker terminals can fry the poor thing). This is the best product we know how to build, but for example, if you mount it to the front bumper of your car, drop it over Niagara Falls, or use it for anchoring your boat, something will go wrong.

Assuming you conform to 1 through 6, and it really isn't all that hard to do, we get the option of fixing your product, or replacing it with a new one, at our discretion.

In the event that your product is out of warranty or not covered under our warranty, you may request to have any damage repaired at our normal "Out of Warranty" repair cost.

Legalese

The warranty above is the only warranty issued by AudioControl. This warranty gives you specific legal rights, and you may also have rights that vary from state to state.

Promises of how well your AudioControl product will work are not implied by this warranty. Other than what we've said we'll do in this warranty, we have no obligation, express or implied. We make no warranty of merchantability or fitness for any particular purpose. Also, neither we nor anyone else who has been involved in the development or manufacture of the unit will have any liability for any incidental, consequential, special, or punitive damages, including but not limited to any lost profits or damage to other parts of your system by hooking up to the unit (whether the claim is one for breach of warranty, negligence of other tort, or any other kind of claim). Some states do not allow limitations of consequential damages.

For more information about this fine product, and for additional details of the limited warranty and repair services, please visit www.audiocontrol.com

For technical questions, please visit www.audiocontrol.com/knowledge-base/

AudioControl, Inc.
22410 70th Avenue West
Mountlake Terrace, WA 98043 USA
Phone: 425-775-8461
email: sound.great@audiocontrol.com

©2023 AudioControl. All rights reserved.

As technology advances, AudioControl reserves the right to continuously change our specifications, like our Pacific Northwest weather, although we are working on changing that as well.

